



MatLab Unit Operation potential improvements for academic use

Matlab™ into Aspen Plus™ case

Carsten Drechsler¹, Juan M. Alava², David W. Agar³

¹Project Coordinator carsten.drechsler@tu-dortmund.de

²PSE Master Student. juan.alava@tu-dortmund.de

³Prof. CVT chair. david.agar@tu-dortmund.de

Presentation Overview

- Software solutions within a research project in University
- Overview of current thesis project
- Matlab Unit Operation (MUO) into Aspen: examples, limitations
- DAC-UNIT current errors - solutions
- MUO User friendly?

Software solutions within a research project in academy

- Development of Mathematical Models, new ideas
- Freedom on choosing the simulation software
- Different software tools = different solution approaches
 - Equation oriented vs modular modeling
 - Steady vs dynamic
- Integration tools required e.g.: CAPE-OPEN Matlab Unit Operation

Thank you CO-LaN!

Overview of current thesis project

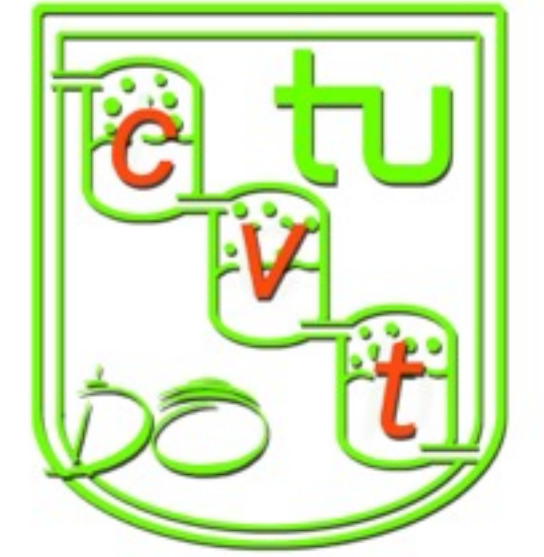

- General research project topic:

“Adsorptive Direct Air Capture of CO₂”

M.Sc. Carsten Drechsler, Prof. David W. Agar

- Thesis topic:

“Optimal cost-based design of a highly integrated thermally coupled DAC-PTG process”

- Among tasks: Existing Matlab (r2013b) rigorous model for the DAC unit should be implemented into Aspen Plus V8.8

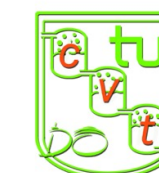

Matlab into Aspen Plus case

- CAPE-OPEN Matlab Unit Operation (MUO) Download and installation

Matlab CAPE-OPEN					
file	size	description	platform	last update	
MatlabCapeOpenUnitOperation.2.0.0.9.exe	1400 KB	Matlab CAPE-OPEN Unit Operation Windows installer.	Windows, Matlab 7.7 (or higher)	28 aug 2018	
MatlabCapeOpenThermoImport.2.0.0.5.exe	943 KB	Matlab CAPE-OPEN Thermo Import installation file.	Windows, Matlab 7.7 (or higher)	28 aug 2018	

- First issue: Compatibility error - solution given by CO-LaN
 - More intuitive error message

Use of the MUO into Aspen Plus V8.8

- Online help guide <https://www.amsterchem.com/matlabunitop.html>
- CAPE-OPEN library in Aspen

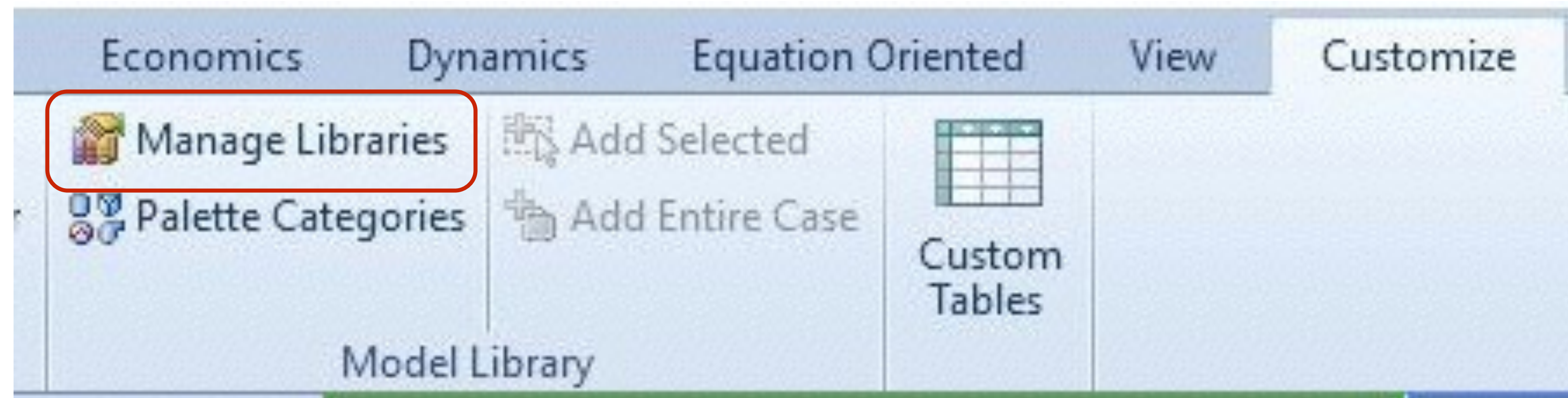

Use of the MUO into Aspen Plus V8.8

- CAPE-OPEN library in Aspen

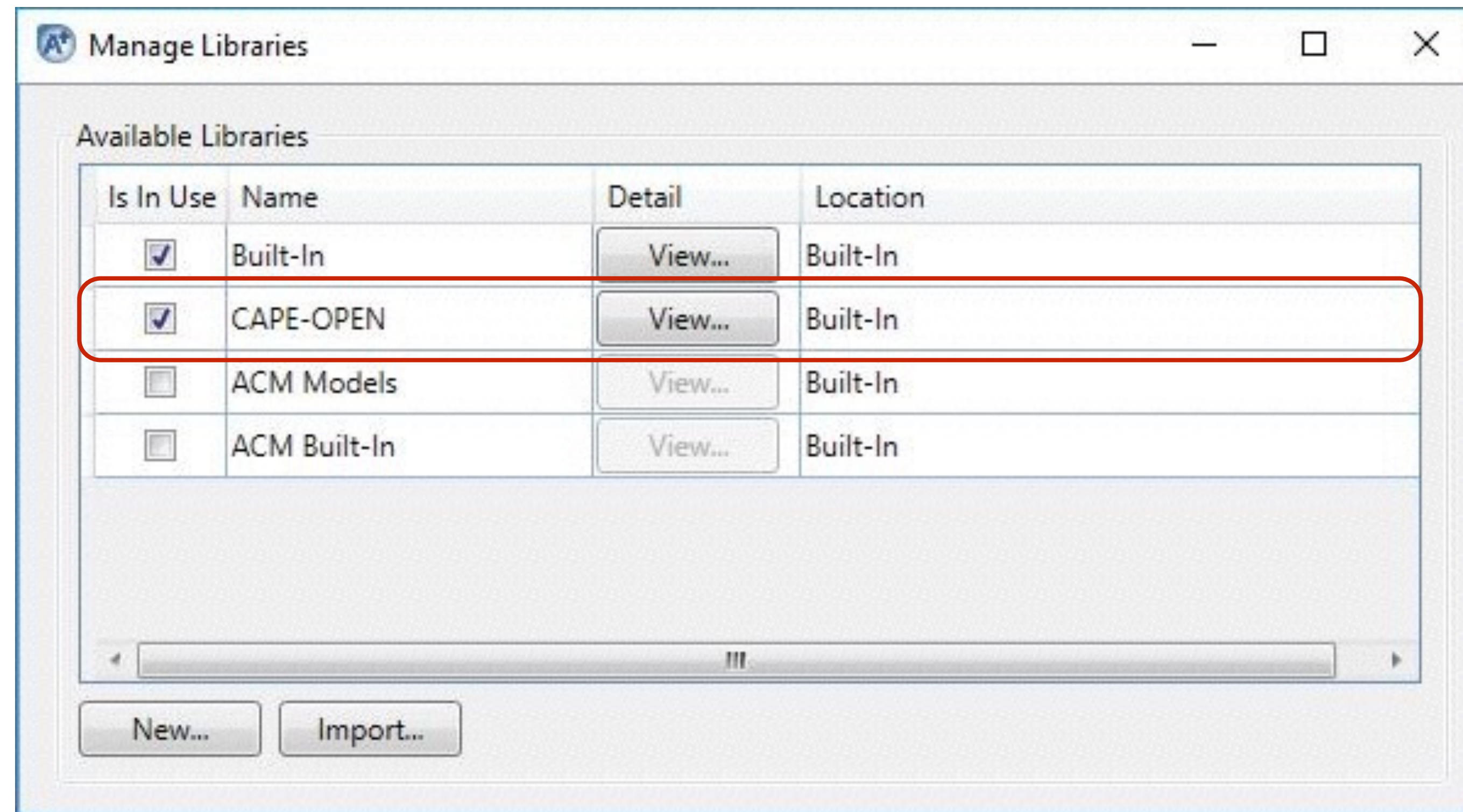

Use of the MUO into Aspen Plus V8.8

- CAPE-OPEN library in Aspen

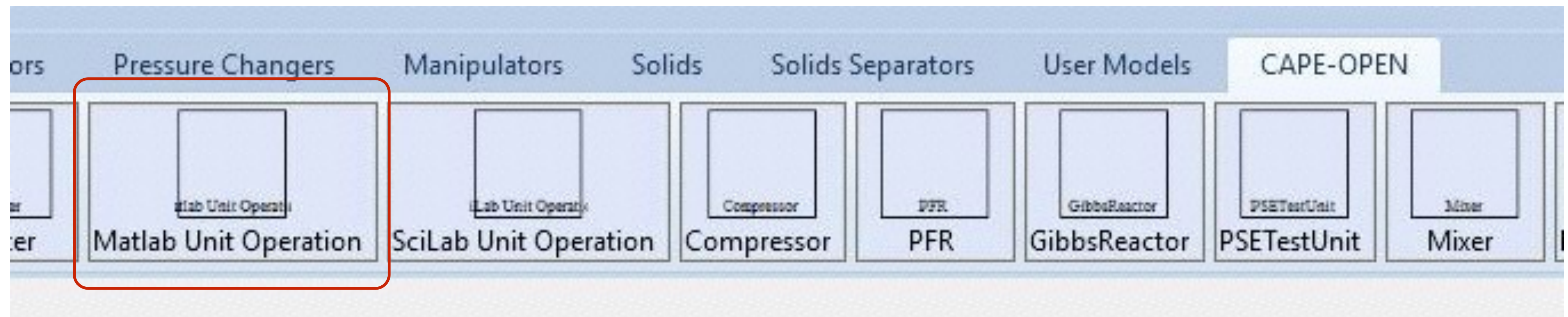

General Example

Matlab Unit Operation with 3 connected streams. No errors

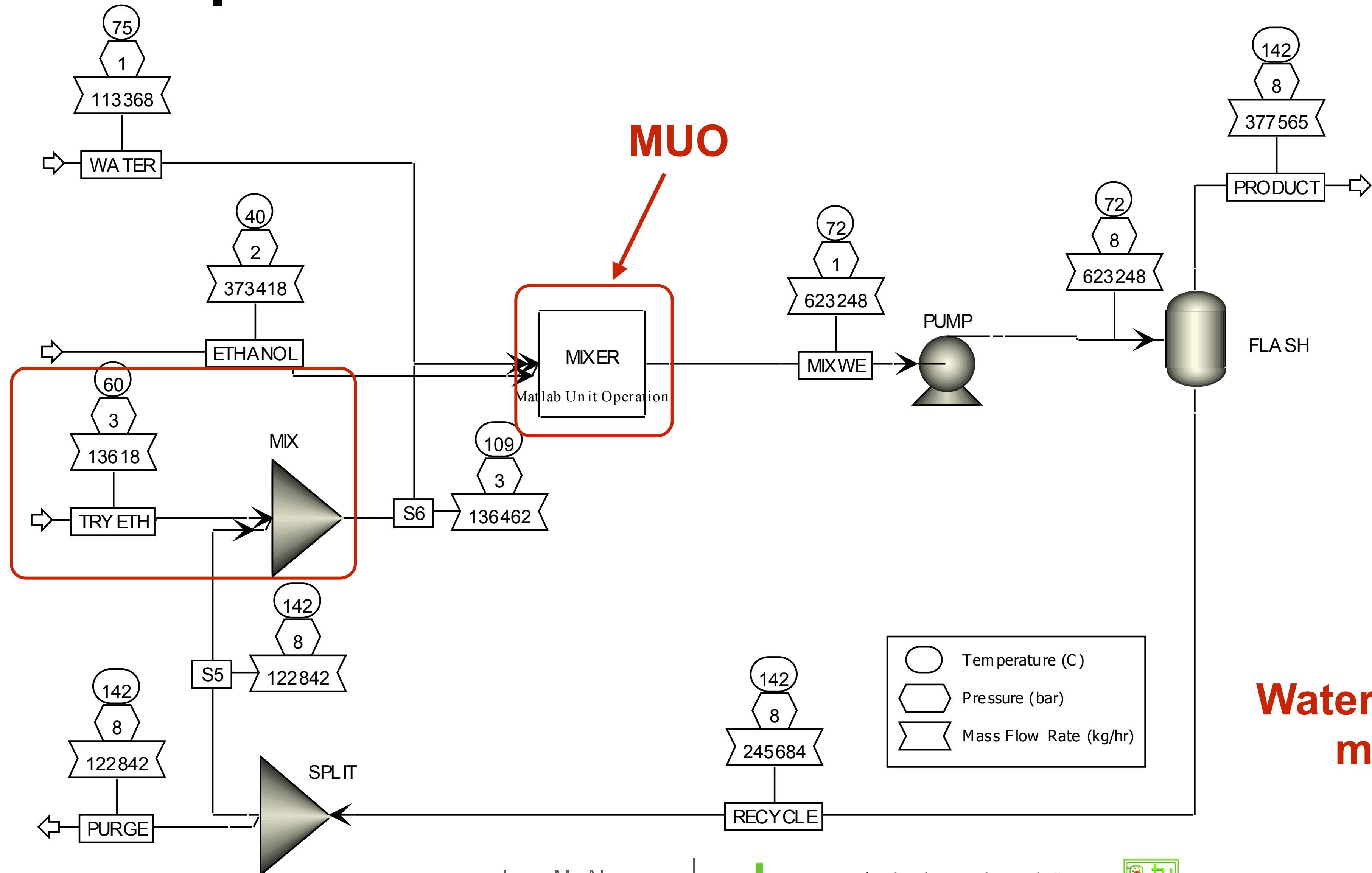

Water / Ethanol mixture

Recycle stream without direct declaration produces errors in the aspen simulation environment

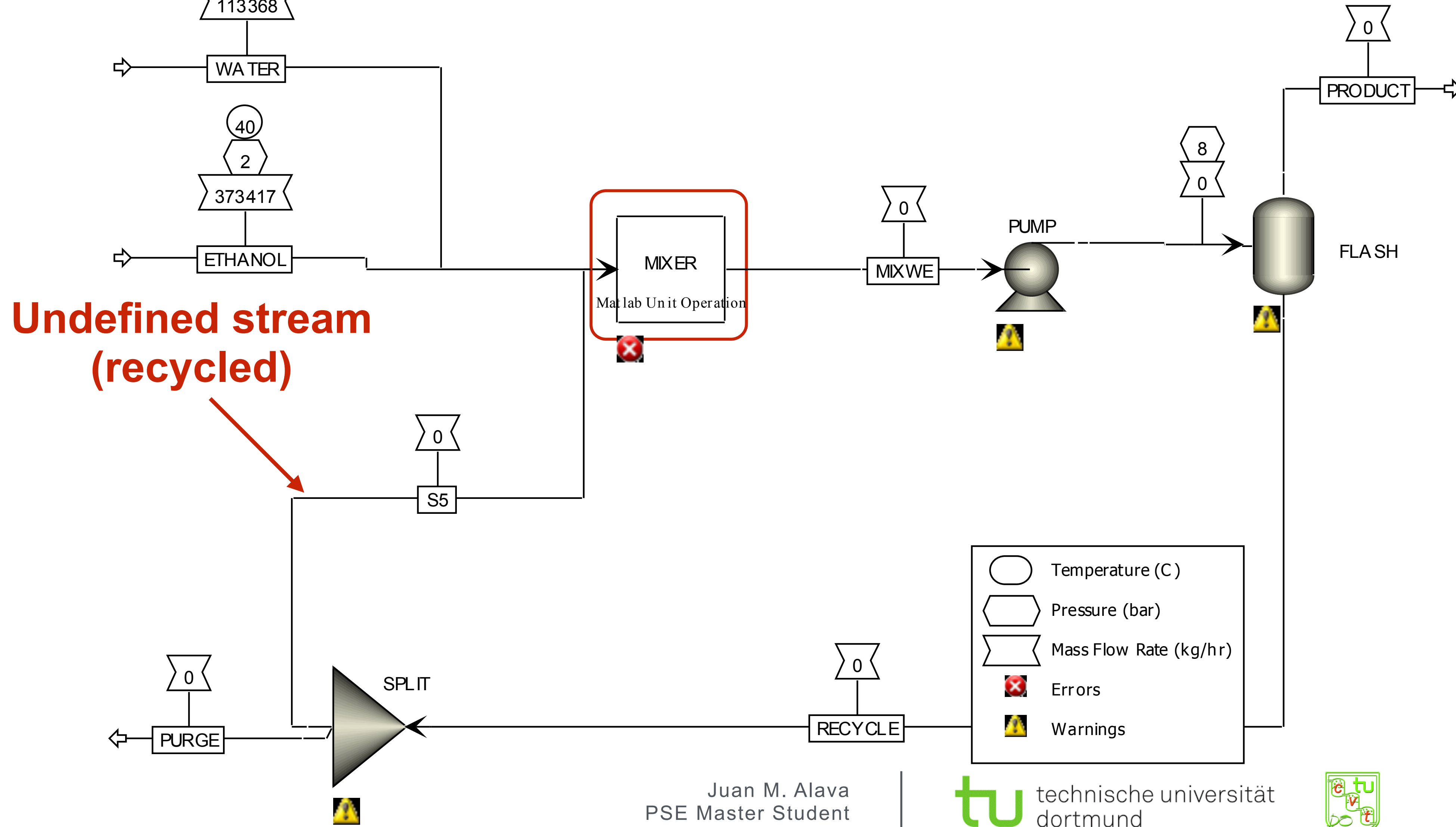

Undefined stream
(recycled)

Recycle stream without direct settings produces errors in the Aspen simulation environment

The screenshot shows the 'Matlab CAPE-OPEN Unit Operation' window. The 'Report' dropdown is set to 'Matlab Output'. The output text is as follows:

```
Valid registration: license type = Academic
Not licensed for commercial use
MATLAB output:
f1 =
  793.3333  373.3333
f2 =
  1.0e+03 *
  0.1402   2.1967
Evaluation error: Error using CapeOpenUnitMex
Failed to get flow from feed 3: Failed to get the Material Object Property: flow
MATLAB done
Error using CapeOpenUnitMex. Failed to get flow from feed 3: Failed to get the Material Object Property: flow
```

A red arrow points from the text 'MUO error for recycled stream' to the error message. Another red arrow points from the text 'Solution?' to the same error message. The error message is enclosed in a red rounded rectangle.

Use of a duplicated MUO with the same code (errors)

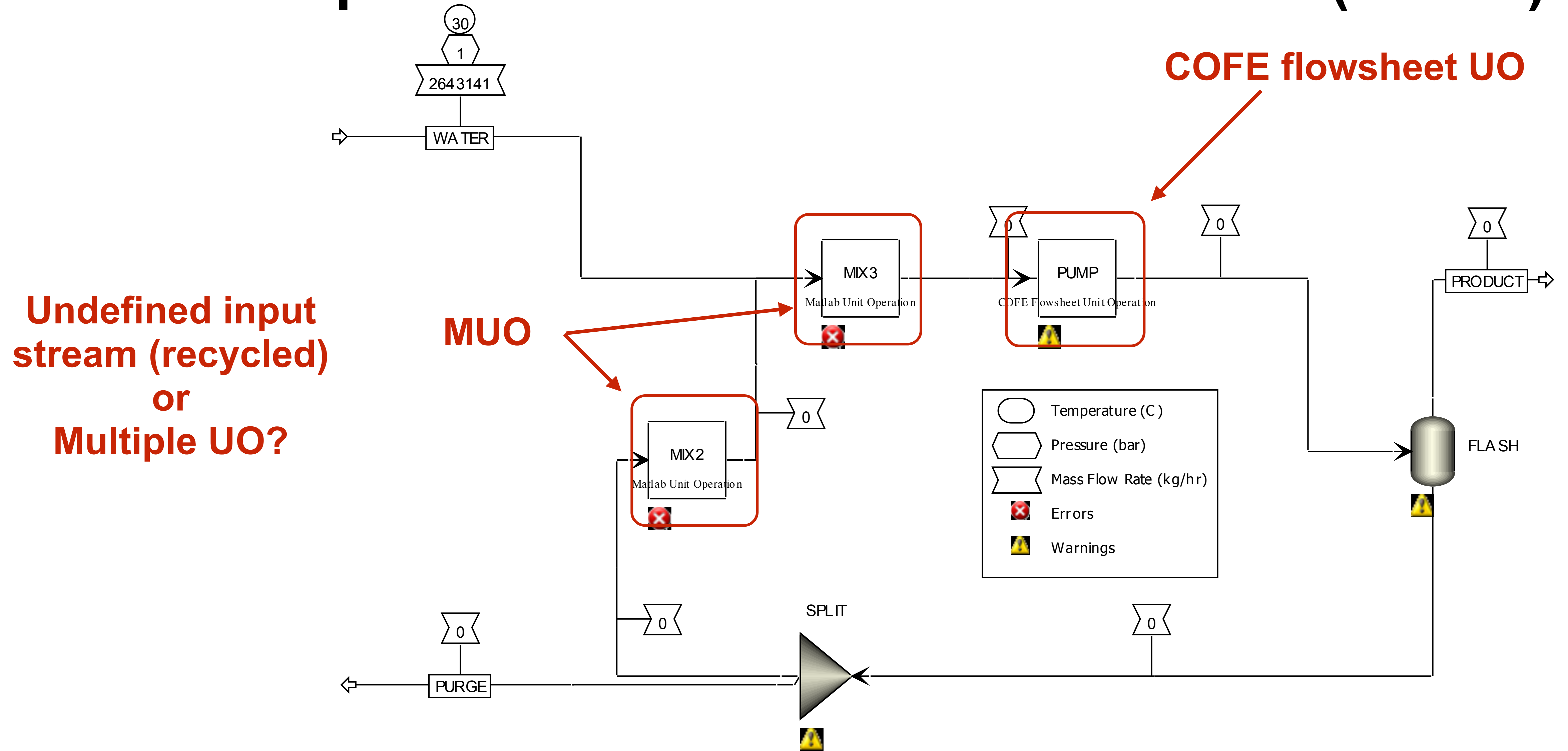

Use of a duplicated MUO with the same code (errors)

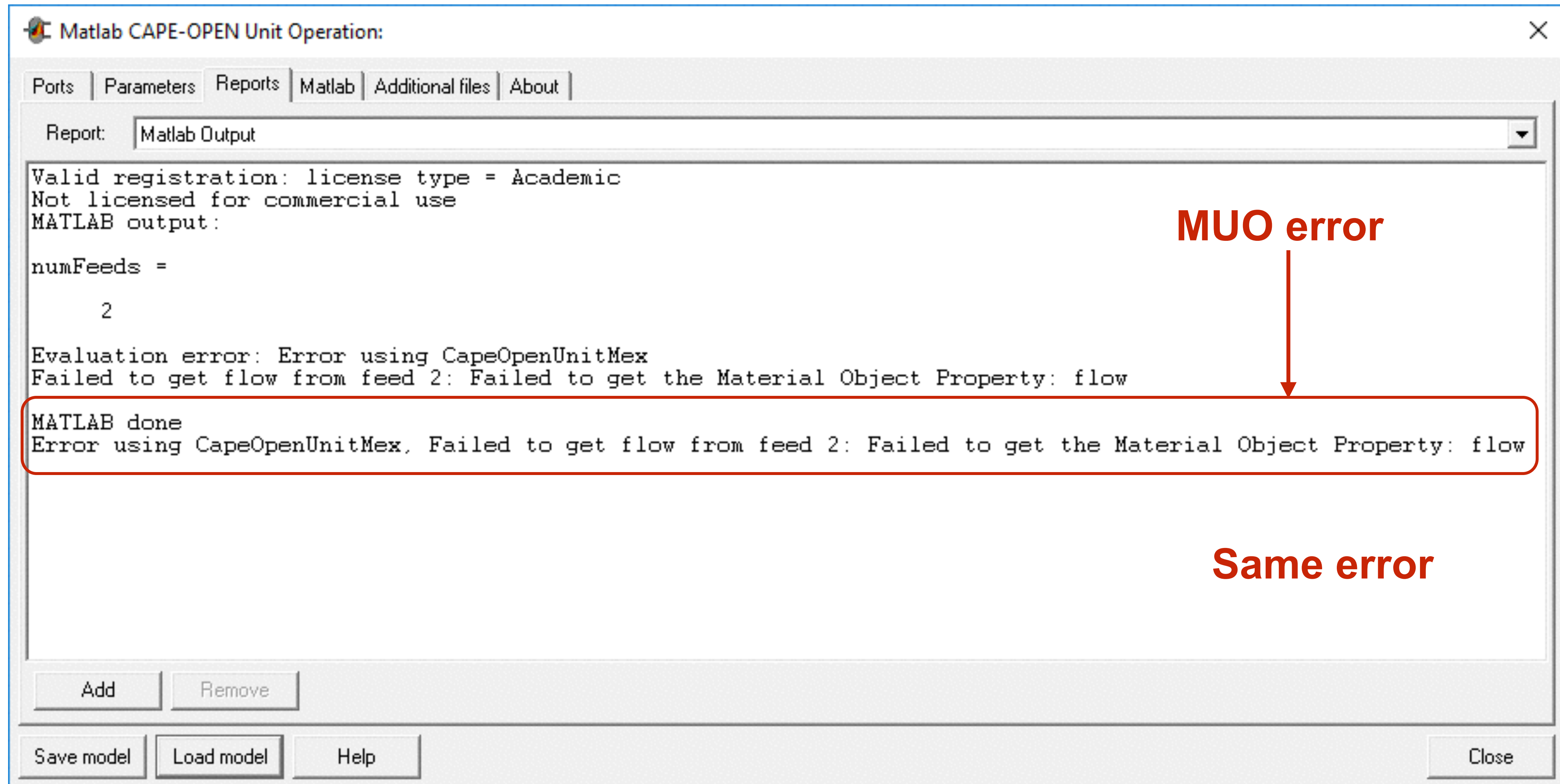

Use of a duplicated cape open Unit with different code (MUO error)

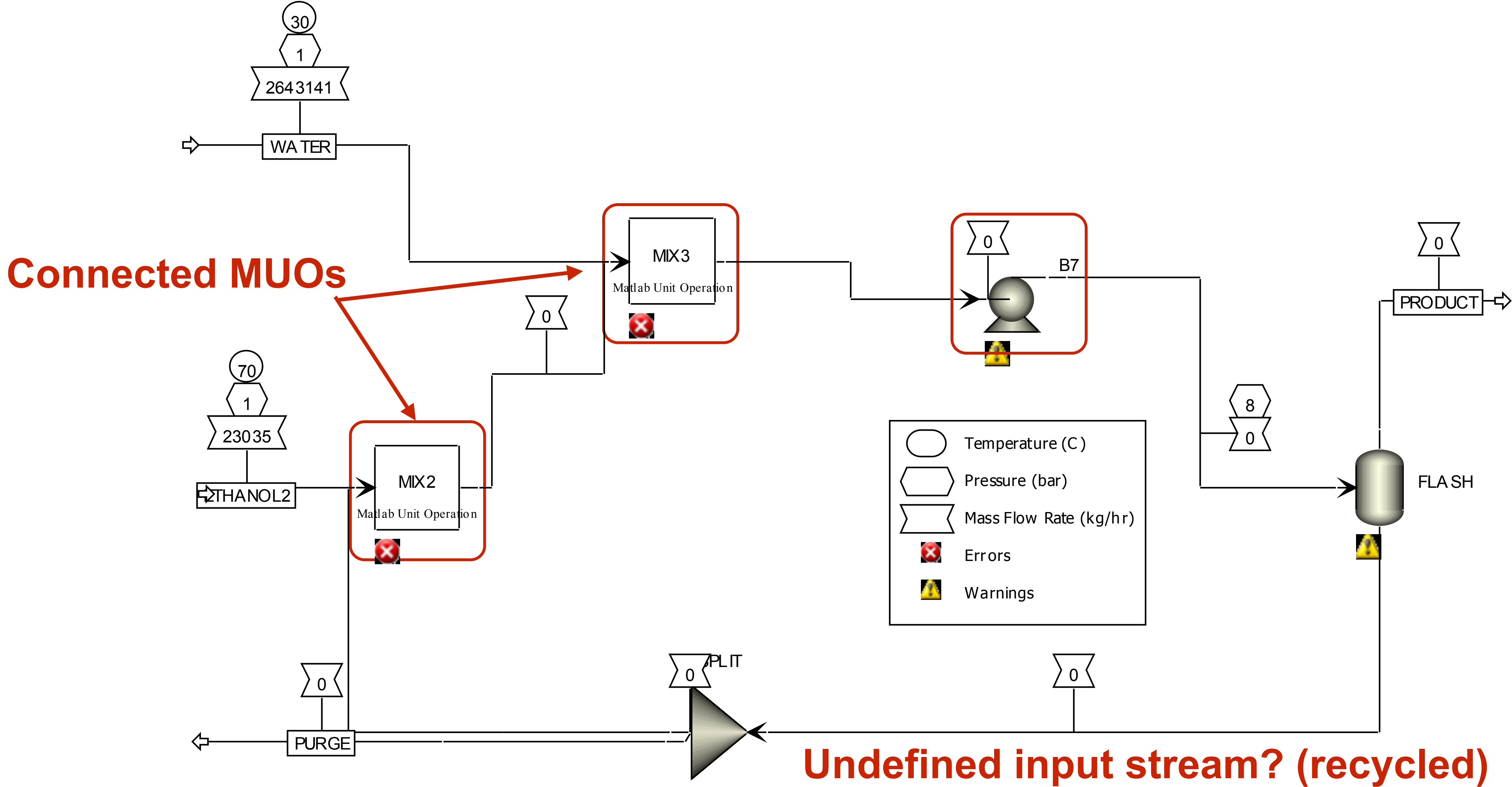

Use of a duplicated MUO with the same code (no error)

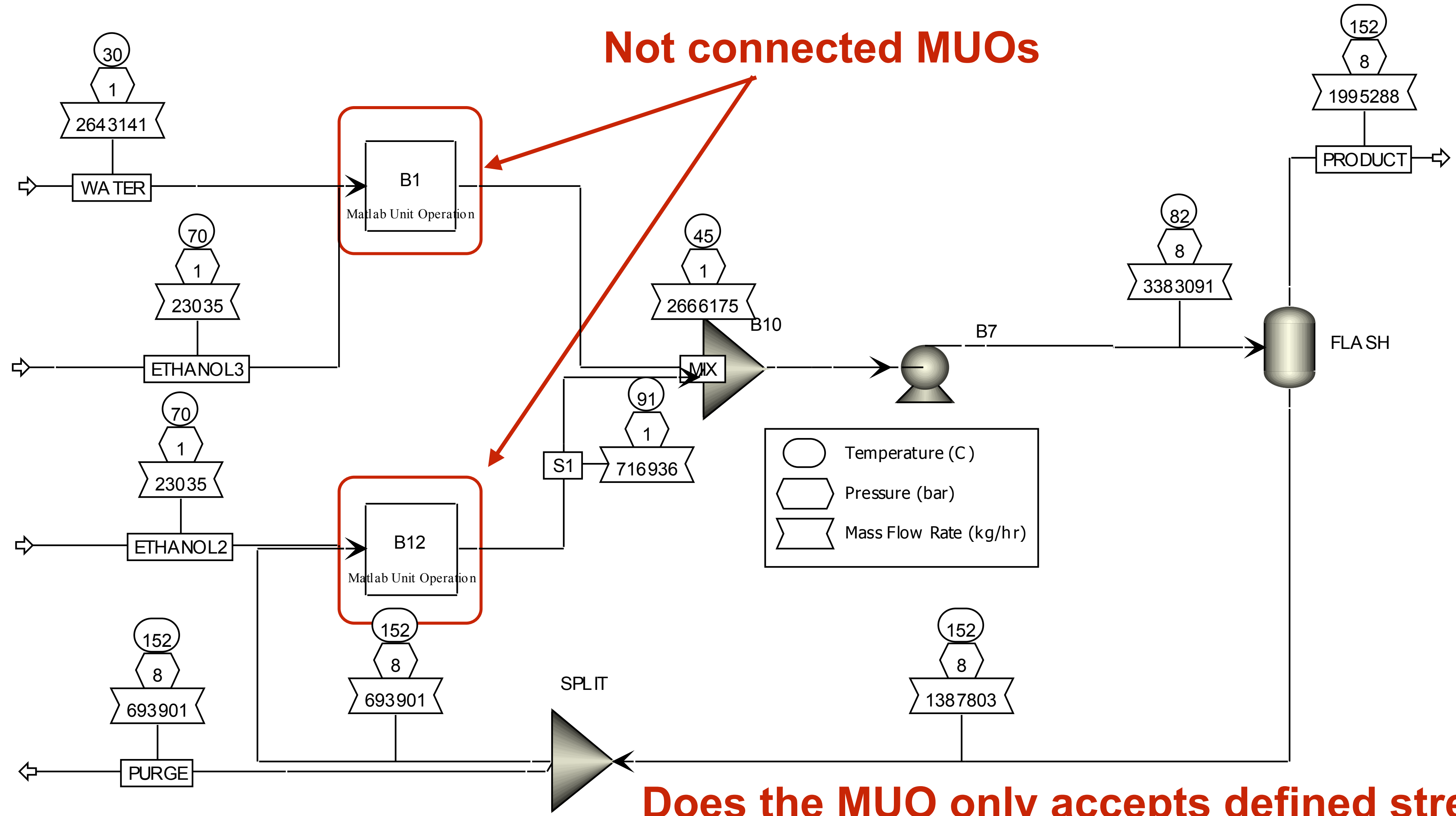

Behaviour of the MUO (DAC-UNIT) in Aspen

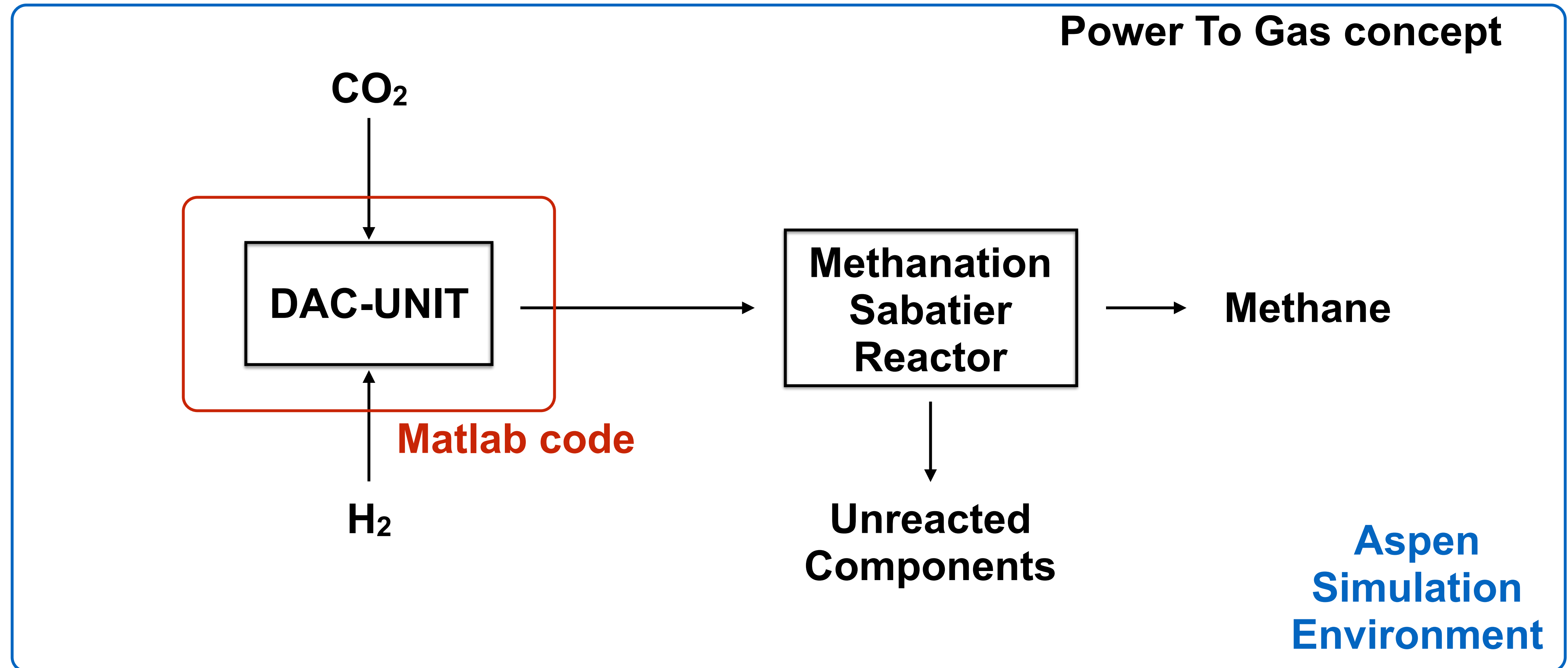

Behaviour of the MUO (DAC-UNIT) in Aspen

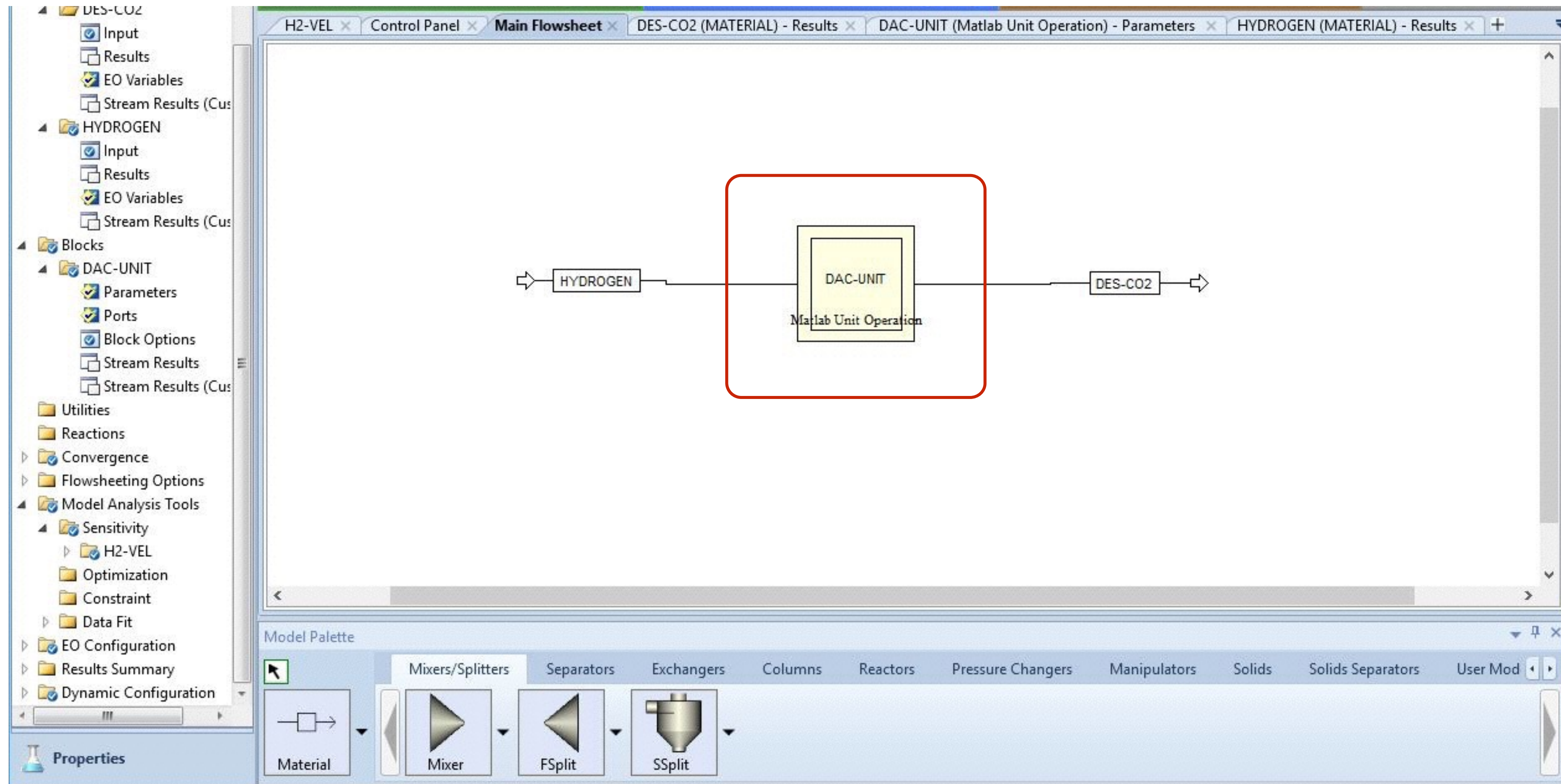

Input specification of the DAC-UNIT in Aspen

- 9 input parameters need to be specified
- So far 7 output parameters and states are obtained from the DAC-UNIT for analysis:
 - Sensitivity analysis
 - Optimisation studies (costs)
 - Design specification

Presented error of the DAC-UNIT in Aspen

- When a simulation error is present the simulation engine stops working
- The streams are disconnected and MUO won't work



Presented error of the DAC-UNIT in Aspen

- Solution: let the Aspen simulation environment restart.

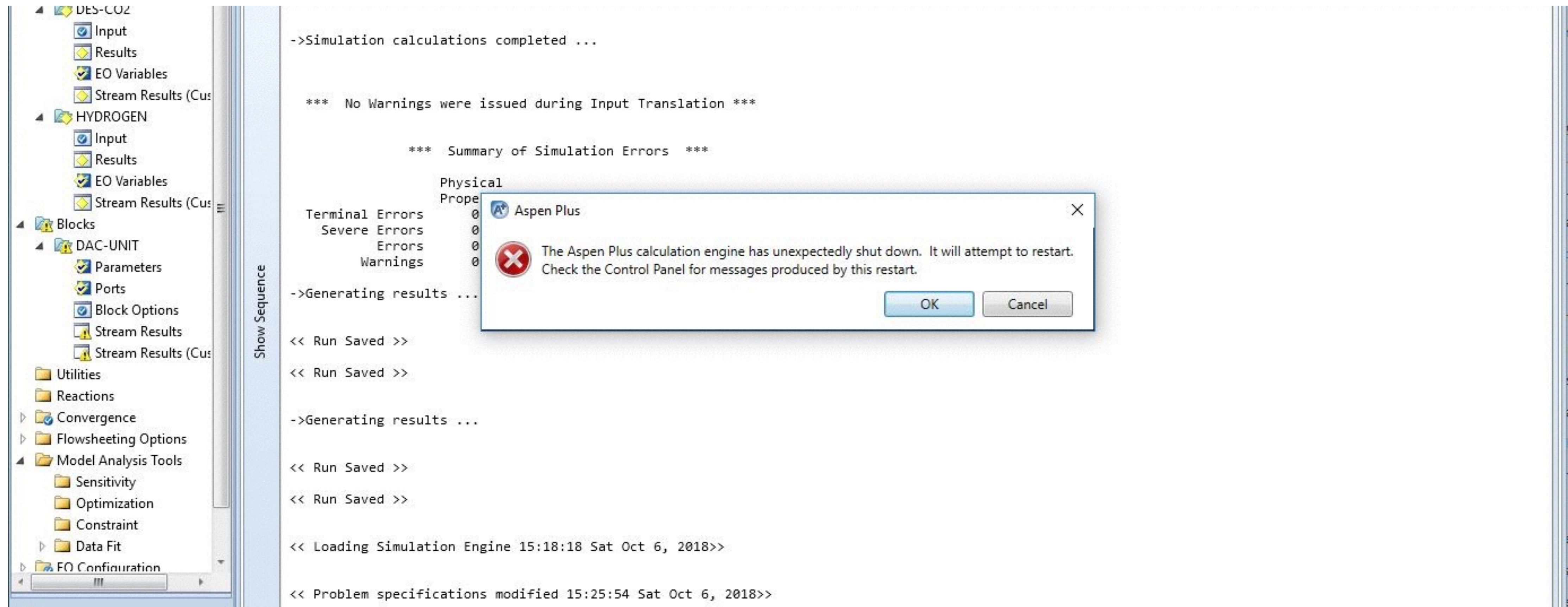

The screenshot displays the Aspen Plus interface. On the left, a tree view shows the process flow diagram with units like DES-CO2, HYDROGEN, and DAC-UNIT. The DAC-UNIT is highlighted with a warning icon. The main window shows the simulation log with the following text:

```
->Simulation calculations completed ...  
  
*** No Warnings were issued during Input Translation ***  
  
*** Summary of Simulation Errors ***  
  
Physical  
Propert  
Terminal Errors 0  
Severe Errors 0  
Errors 0  
Warnings 0  
  
->Generating results ...  
  
<< Run Saved >>  
<< Run Saved >>  
  
->Generating results ...  
  
<< Run Saved >>  
<< Run Saved >>  
  
<< Loading Simulation Engine 15:18:18 Sat Oct 6, 2018>>  
  
<< Problem specifications modified 15:25:54 Sat Oct 6, 2018>>
```

An error dialog box titled "Aspen Plus" is overlaid on the log. It contains the following text:

The Aspen Plus calculation engine has unexpectedly shut down. It will attempt to restart. Check the Control Panel for messages produced by this restart.

The dialog box has "OK" and "Cancel" buttons.

Presented error of the DAC-UNIT in Aspen

- Solution: let the Aspen simulation environment restart
- Disconnect the input / output streams
- Reset the simulation (reset button)
- Edit the MUO by loading the .mum file for the DAC-Unit
- Reconnect the streams
- Run the simulation

Current diagnostic and solution by CO-LaN

- Use the COLTT application to understand the source of the problem
 - COLTT 2.4.0 Controller x64

General Improvements on MUO

- Include a default port to be declared after the stream connection.
- Allow copy and paste of parameters in the parameter declaration tab.
- Allow several Matlab file scripts to be selected and incorporated in the additional files tab.
- Current online help content related to the MUO should be integrated into the MUO dialog window.
- Improvement on working with recycle streams (undefined stream).
- Improvement on Aspen to MUO communication.

Thanks for your attention

