

# A look into the CAPE-OPEN kitchen of



**COCO**

**Jasper van Baten, AmsterCHEM**

## **CAPE-OPEN to CAPE-OPEN (COCO):**



Simulation environment (COFE)



Thermodynamic property package (TEA)



Collection of unit operations (COUS)



Reaction package (CORN)



## COFE: CAPE-OPEN Flowsheeting Environment

### GUI:

- Graphical flowsheet editing
- Compact display of streams
- Quick access to CO objects
- Property graphing & printing
- Extensive help

### Flowsheeting:

- Steady state
- Solution by tearing algorithm
- Multiple material templates

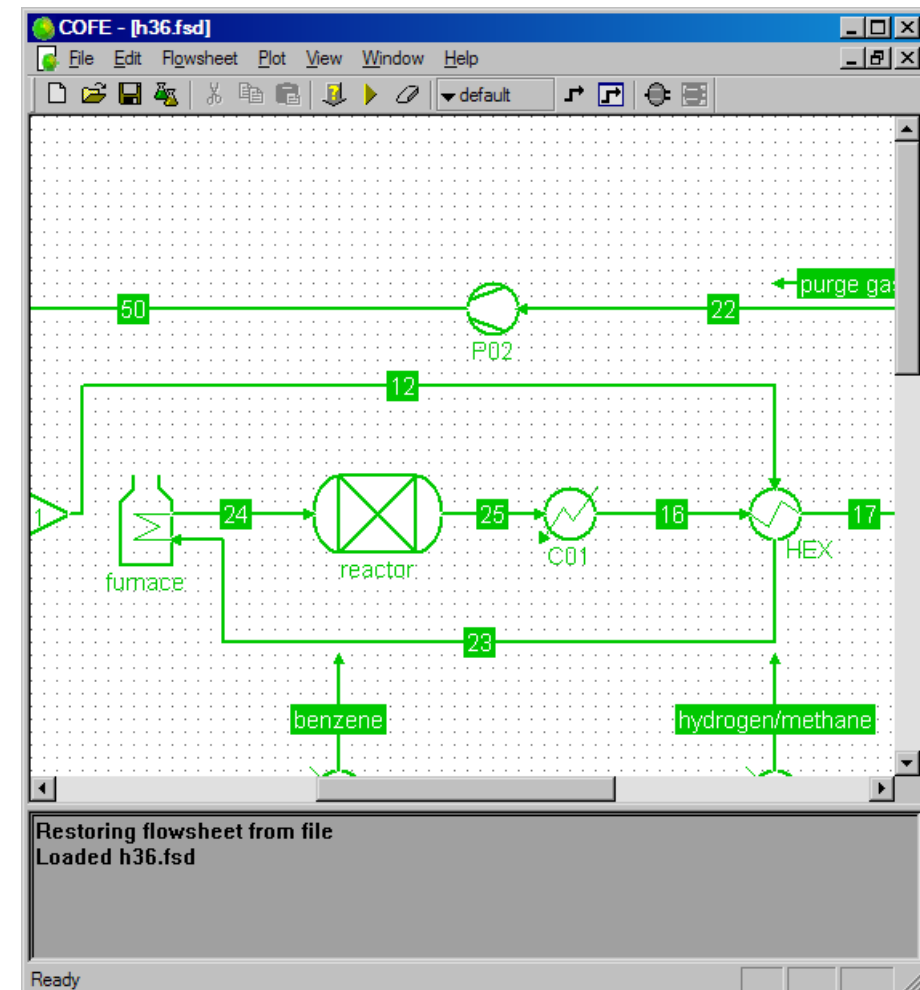



## TEA: Thermodynamics for Engineering Applications

- Pure compound data library (extendible, or use DIPPR)
- 100+ Property calculation methods (> 25 different properties)
- Property derivatives
- Support of external property calculation routines (ICapeThermoCalculationRoutines)

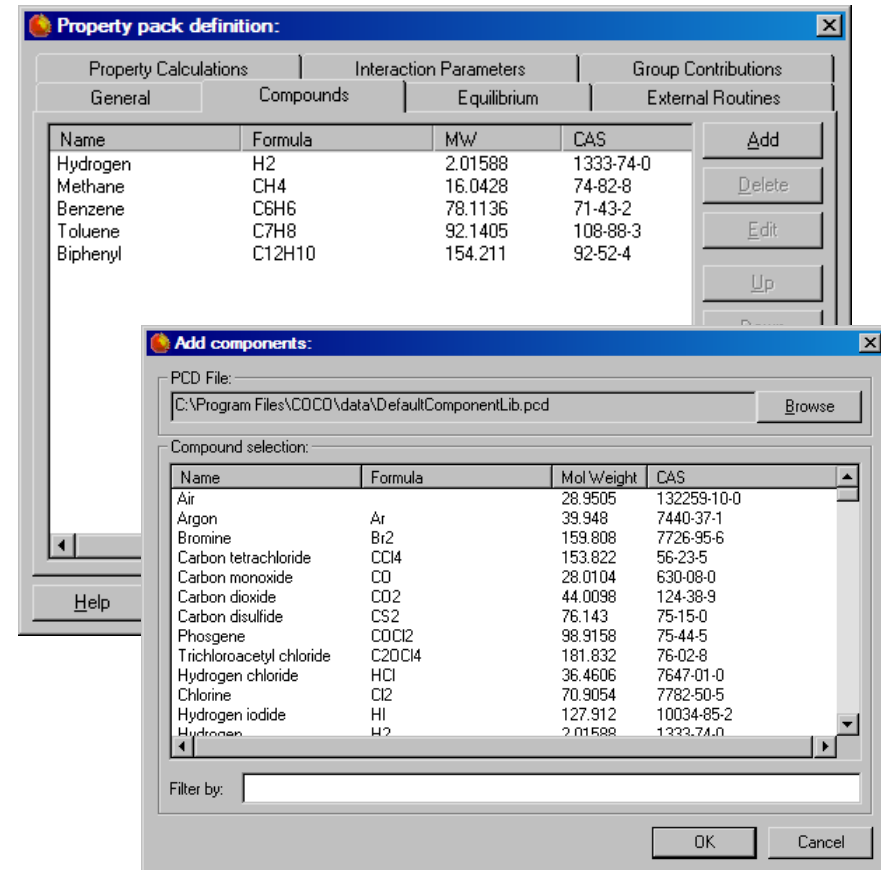

Thermodynamic models and compounds from ChemSep



## COUS-COUS: Simple unit operations

- General purpose unit operations (mixer, splitter, heat exchanger...)
- Property tester for thermodynamic properties
- Distillation column of ChemSep LITE

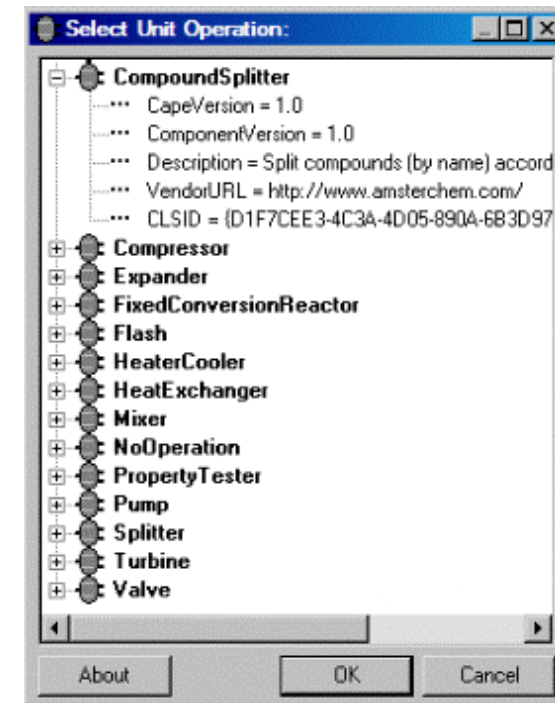

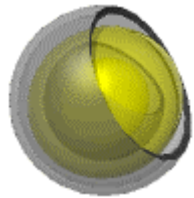

## CORN: CAPE-OPEN Reaction Numerics

- Currently the only reaction package manager around
- Kinetic and equilibrium reactions
- Formula interpreter for rates, equilibrium constants, and heats of reaction
- COFE and COUS support reaction packages, i.e. CORN

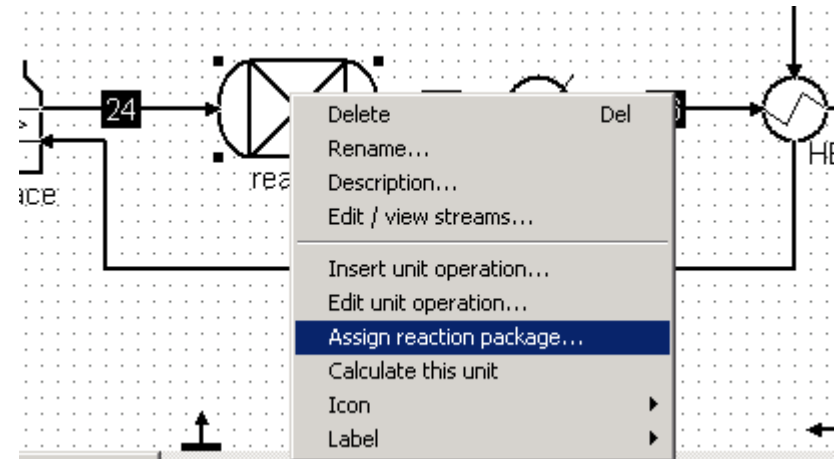

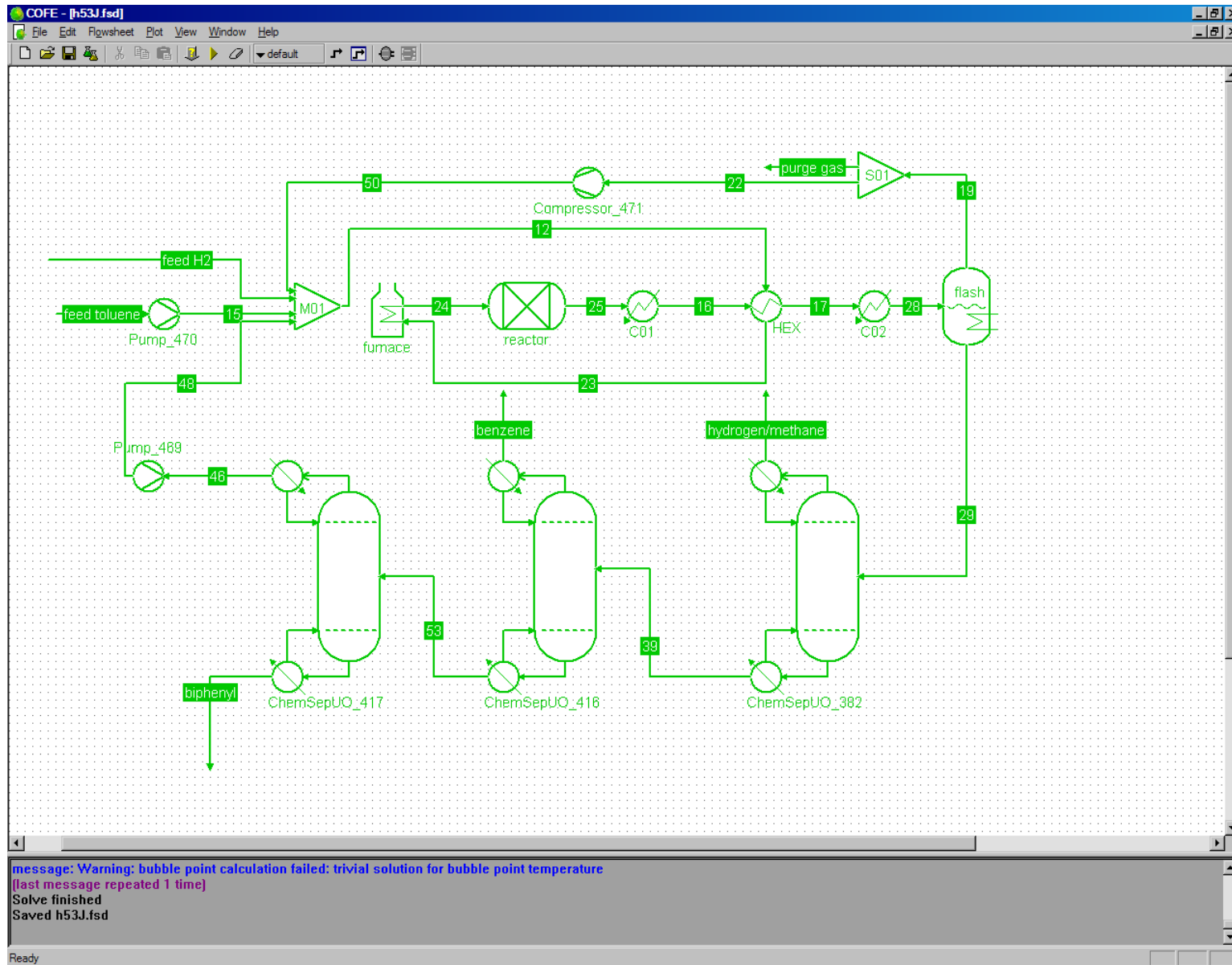

## HDA case study

## Thermodynamics Interoperability tests:

	TEA <sup>1)</sup>	Aspen thermo	Simulis
COFE	✓	✓ ✗ <sup>2)</sup>	✓
Aspen Plus	✓		
Pro/II	✗ <sup>3)</sup>		
Simulis	✓		

- 1) TEA is currently the only support for ICapeThermoCalculationRoutines (e.g. CosmoTherm)
- 2) Equilibrium calculations ok, properties fail. Problem with compound IDs, being looked into by Aspen
- 3) Problem with resolving compound IDs inside Pro/II

## Unit-operation Interoperability tests:

	COUS	ChemSep	Aspen Mixer
COFE	✓	✓	✗ <sup>1)</sup>
Aspen Plus	✓ ✗ <sup>2)</sup>		
Pro/II	✓ ✗ <sup>3)</sup>		

- 1) Overall enthalpy calculations fail
- 2) Enthalpy is requested without basis (mass or mole)
- 3) Equilibrium calculations fail for specified enthalpy

The image displays two overlapping windows from the Aspen Plus 2004.1 software. The background window is the 'Process Flowsheet Window' showing a reactor block with four streams labeled 1, 2, 3, and 4. The foreground window is the 'Block B1 (Flash3) Stream Results - Data Browser' window, which displays a table of stream results for a reactor block.

**Stream Results Data Table:**

	1	2	3	4
WATER	.7000000	0.0	.2134422	.4865578
N-BU-1	.3000000	0.0	.2793066	.0206934
Total Flow kmol/sec	1.000000	0.0	.4927488	.5072512
Total Flow kg/sec	34.84754	0.0	24.54821	10.29933
Total Flow cum/sec	.0365687	0.0	.0301741	.0110802
Temperature K	333.1500		333.1500	333.1500
Pressure N/sqm	1.00000E+5	1.00000E+5	1.00000E+5	1.00000E+5
Vapor Frac	0.0		0.0	0.0
Liquid Frac	1.000000		1.000000	1.000000
Solid Frac	0.0		0.0	0.0
Enthalpy J/kmol	-4.1611E+7		-3.0447E+8	-2.8534E+8
Enthalpy J/kg	-1.1941E+6		-6.1116E+6	-1.4053E+7
Enthalpy Watt	-4.1611E+7		-1.5003E+8	-1.4474E+8
Entropy J/kmol-K	1.16881E+5		-3.6773E+5	-1.7179E+5
Entropy J/kg-K	3354.066		-7381.353	-8460.652
Density kmol/cum	27.34577		16.33015	45.77983

## TEA using CosmoTherm in AspenPlus 2004.1

## **COCO serves you with:**

- CAPE-OPEN based flowsheet solver
- Good interoperability; mix in any unit you like
- All flavors of thermodynamic and physical properties
- Support for external property calculation routines
- The ultimate tester for CAPE-OPEN compatibility

## **Still on the stove:**

- CAPE-OPEN version 1.1 thermodynamics
- Excel interface to COFE
- Petroleum fractions
- Additional unit operations
- External equilibrium routines (currently disabled)
- In-/export of numeric interfaces
- ...

- Download COCO: <http://www.amsterchem.com/>  
(or ask for a copy during the workshop)
- Contact AmsterCHEM for CAPE-OPEN consulting

---

**Acknowledgements:**

- Richard Baur
- ChemSep: Harry Kooijman, Ross Taylor
- Michel Pons
- CosmoLogic: Andreas Klamt, Frank Eckert
- Aspen Technology